

## Quad 2-input OR gate

## 74HC32; 74HCT32

## FEATURES

- Wide supply voltage range from 2.0 to 6.0 V
- Symmetrical output impedance
- High noise immunity
- Low power dissipation
- Balanced propagation delays
- ESD protection:  
HBM EIA/JESD22-A114-A exceeds 2000 V  
MM EIA/JESD22-A115-A exceeds 200 V.

## GENERAL DESCRIPTION

The 74HC/HCT32 is a high-speed Si-gate CMOS device and is pin compatible with low power Schottky TTL (LSTTL). They are specified in compliance with JEDEC standard no. 7A.

The 74HC/HCT32 provides the 2-input OR function.

## QUICK REFERENCE DATA

GND = 0 V;  $T_{amb} = 25\text{ }^{\circ}\text{C}$ ;  $t_r = t_f = 6\text{ ns}$ .

SYMBOL	PARAMETER	CONDITIONS	TYPICAL		UNIT
			HC	HCT	
$t_{PHL}/t_{PLH}$	propagation delay nA, nB to nY	$C_L = 15\text{ pF}$ ; $V_{CC} = 5\text{ V}$	6	9	ns
$C_I$	input capacitance		3.5	3.5	pF
$C_{PD}$	power dissipation capacitance per gate	notes 1 and 2	16	28	pF

## Notes

1.  $C_{PD}$  is used to determine the dynamic power dissipation ( $P_D$  in  $\mu\text{W}$ ).

$$P_D = C_{PD} \times V_{CC}^2 \times f_i \times N + \Sigma(C_L \times V_{CC}^2 \times f_o) \text{ where:}$$

$f_i$  = input frequency in MHz;

$f_o$  = output frequency in MHz;

$C_L$  = output load capacitance in pF;

$V_{CC}$  = supply voltage in Volts;

$N$  = total load switching outputs;

$\Sigma(C_L \times V_{CC}^2 \times f_o)$  = sum of the outputs.

2. For 74HC32 the condition is  $V_I = \text{GND to } V_{CC}$ .

For 74HCT32 the condition is  $V_I = \text{GND to } V_{CC} - 1.5\text{ V}$ .

## FUNCTION TABLE

See note 1.

INPUT		OUTPUT
nA	nB	nY
L	L	L
L	H	H
H	L	H
H	H	H

## Note

1. H = HIGH voltage level;  
L = LOW voltage level.

# Quad 2-input OR gate

# 74HC32; 74HCT32

## ORDERING INFORMATION

TYPE NUMBER	PACKAGE				
	TEMPERATURE RANGE	PINS	PACKAGE	MATERIAL	CODE
74HC32N	-40 to +125 °C	14	DIP14	plastic	SOT27-1
74HCT32N	-40 to +125 °C	14	DIP14	plastic	SOT27-1
74HC32D	-40 to +125 °C	14	SO14	plastic	SOT108-1
74HCT32D	-40 to +125 °C	14	SO14	plastic	SOT108-1
74HC32DB	-40 to +125 °C	14	SSOP14	plastic	SOT337-1
74HCT32DB	-40 to +125 °C	14	SSOP14	plastic	SOT337-1
74HC32PW	-40 to +125 °C	14	TSSOP14	plastic	SOT402-1
74HCT32PW	-40 to +125 °C	14	TSSOP14	plastic	SOT402-1
74HC32BQ	-40 to +125 °C	14	DHVQFN14	plastic	SOT762-1
74HCT32BQ	-40 to +125 °C	14	DHVQFN14	plastic	SOT762-1

## PINNING

PIN	SYMBOL	DESCRIPTION
1	1A	data input
2	1B	data input
3	1Y	data output
4	2A	data input
5	2B	data input
6	2Y	data output
7	GND	ground (0 V)
8	3Y	data output
9	3A	data input
10	3B	data input
11	4Y	data output
12	4A	data input
13	4B	data input
14	V <sub>CC</sub>	supply voltage

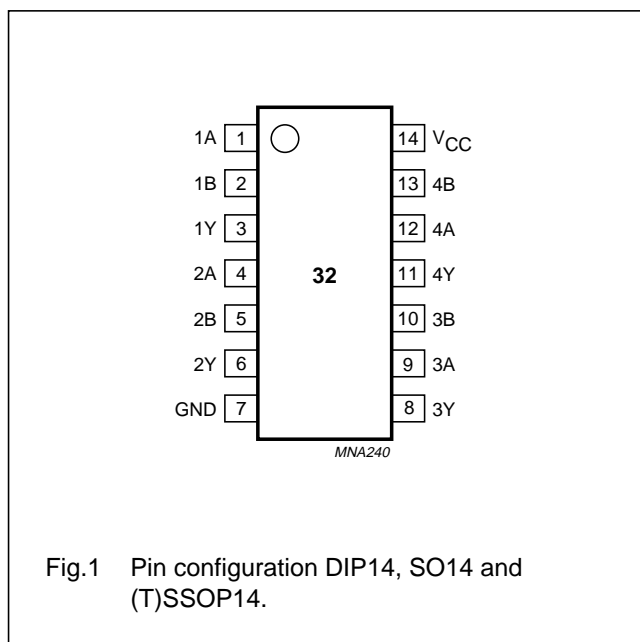

## Quad 2-input OR gate

## 74HC32; 74HCT32

## RECOMMENDED OPERATING CONDITIONS

SYMBOL	PARAMETER	CONDITIONS	74HC32			74HCT32			UNIT
			MIN.	TYP.	MAX.	MIN.	TYP.	MAX.	
$V_{CC}$	supply voltage		2.0	5.0	6.0	4.5	5.0	5.5	V
$V_I$	input voltage		0	–	$V_{CC}$	0	–	$V_{CC}$	V
$V_O$	output voltage		0	–	$V_{CC}$	0	–	$V_{CC}$	V
$T_{amb}$	operating ambient temperature		–40	+25	+125	–40	+25	+125	°C
$t_r, t_f$	input rise and fall times	$V_{CC} = 2.0\text{ V}$	–	–	1000	–	–	–	ns
		$V_{CC} = 4.5\text{ V}$	–	6.0	500	–	6.0	500	ns
		$V_{CC} = 6.0\text{ V}$	–	–	400	–	–	–	ns

## LIMITING VALUES

In accordance with the Absolute Maximum Rating System (IEC 60134); voltages are referenced to GND (ground = 0 V).

SYMBOL	PARAMETER	CONDITIONS	MIN.	MAX.	UNIT
$V_{CC}$	supply voltage		–0.5	+7.0	V
$I_{IK}$	input diode current	$V_I < -0.5\text{ V}$ or $V_I > V_{CC} + 0.5\text{ V}$ ; note 1	–	±20	mA
$I_{OK}$	output diode current	$V_O < -0.5\text{ V}$ or $V_O > V_{CC} + 0.5\text{ V}$ ; note 1	–	±20	mA
$I_O$	output source or sink current	$-0.5\text{ V} < V_O < V_{CC} + 0.5\text{ V}$ ; note 1	–	±25	mA
$I_{CC}; I_{GND}$	$V_{CC}$ or GND current	note 1	–	±50	mA
$T_{stg}$	storage temperature		–65	+150	°C
$P_{tot}$	power dissipation	$T_{amb} = -40\text{ to }+125\text{ °C}$ ; note 2	–	300	mW

## Notes

- The input and output voltage ratings may be exceeded if the input and output current ratings are observed.
- For DIP14 packages: above 70 °C the value of  $P_{tot}$  derates linearly with 12 mW/K.  
For SO14 packages: above 70 °C the value of  $P_{tot}$  derates linearly with 8 mW/K.  
For SSOP14 and TSSOP14 packages: above 60 °C the value of  $P_{tot}$  derates linearly with 5.5 mW/K.  
For DHVQFN14 packages: above 60 °C the value of  $P_{tot}$  derates linearly with 4.5 mW/K.

## Quad 2-input OR gate

## 74HC32; 74HCT32

## DC CHARACTERISTICS

## Family 74HC

At recommended operating conditions; voltages are referenced to GND (ground = 0 V).

SYMBOL	PARAMETER	CONDITIONS		MIN.	TYP.	MAX.	UNIT
		OTHER	V <sub>CC</sub> (V)				
<b>T<sub>amb</sub> = 25 °C; note 1</b>							
V <sub>IH</sub>	HIGH-level input voltage		2.0	1.5	1.2	–	V
			4.5	3.15	2.4	–	V
			6.0	4.2	3.2	–	V
V <sub>IL</sub>	LOW-level input voltage		2.0	–	0.8	0.5	V
			4.5	–	2.1	1.35	V
			6.0	–	2.8	1.8	V
V <sub>OH</sub>	HIGH-level output voltage	V <sub>I</sub> = V <sub>IH</sub> or V <sub>IL</sub> I <sub>O</sub> = –20 µA	2.0	1.9	2.0	–	V
		I <sub>O</sub> = –20 µA	4.5	4.4	4.5	–	V
		I <sub>O</sub> = –20 µA	6.0	5.9	6.0	–	V
		I <sub>O</sub> = –4.0 mA	4.5	3.98	4.32	–	V
		I <sub>O</sub> = –5.2 mA	6.0	5.48	5.81	–	V
V <sub>OL</sub>	LOW-level output voltage	V <sub>I</sub> = V <sub>IH</sub> or V <sub>IL</sub> I <sub>O</sub> = 20 µA	2.0	–	0	0.1	V
		I <sub>O</sub> = 20 µA	4.5	–	0	0.1	V
		I <sub>O</sub> = 20 µA	6.0	–	0	0.1	V
		I <sub>O</sub> = 4.0 mA	4.5	–	0.15	0.26	V
		I <sub>O</sub> = 5.2 mA	6.0	–	0.16	0.26	V
I <sub>LI</sub>	input leakage current	V <sub>I</sub> = V <sub>CC</sub> or GND	6.0	–	–	±0.1	µA
I <sub>CC</sub>	quiescent supply current	V <sub>I</sub> = V <sub>CC</sub> or GND; I <sub>O</sub> = 0	6.0	–	–	2.0	µA

## Quad 2-input OR gate

## 74HC32; 74HCT32

SYMBOL	PARAMETER	CONDITIONS		MIN.	TYP.	MAX.	UNIT
		OTHER	V <sub>CC</sub> (V)				
<b>T<sub>amb</sub> = -40 to +85 °C</b>							
V <sub>IH</sub>	HIGH-level input voltage		2.0	1.5	–	–	V
			4.5	3.15	–	–	V
			6.0	4.2	–	–	V
V <sub>IL</sub>	LOW-level input voltage		2.0	–	–	0.5	V
			4.5	–	–	1.35	V
			6.0	–	–	1.8	V
V <sub>OH</sub>	HIGH-level output voltage	V <sub>I</sub> = V <sub>IH</sub> or V <sub>IL</sub> I <sub>O</sub> = -20 µA	2.0	1.9	–	–	V
		I <sub>O</sub> = -20 µA	4.5	4.4	–	–	V
		I <sub>O</sub> = -20 µA	6.0	5.9	–	–	V
		I <sub>O</sub> = -4.0 mA	4.5	3.84	–	–	V
		I <sub>O</sub> = -5.2 mA	6.0	5.34	–	–	V
V <sub>OL</sub>	LOW-level output voltage	V <sub>I</sub> = V <sub>IH</sub> or V <sub>IL</sub> I <sub>O</sub> = 20 µA	2.0	–	–	0.1	V
		I <sub>O</sub> = 20 µA	4.5	–	–	0.1	V
		I <sub>O</sub> = 20 µA	6.0	–	–	0.1	V
		I <sub>O</sub> = 4.0 mA	4.5	–	–	0.33	V
		I <sub>O</sub> = 5.2 mA	6.0	–	–	0.33	V
I <sub>LI</sub>	input leakage current	V <sub>I</sub> = V <sub>CC</sub> or GND	6.0	–	–	±1.0	µA
I <sub>CC</sub>	quiescent supply current	V <sub>I</sub> = V <sub>CC</sub> or GND; I <sub>O</sub> = 0	6.0	–	–	20	µA

## Quad 2-input OR gate

## 74HC32; 74HCT32

SYMBOL	PARAMETER	CONDITIONS		MIN.	TYP.	MAX.	UNIT
		OTHER	V <sub>CC</sub> (V)				
<b>T<sub>amb</sub> = -40 to +125 °C</b>							
V <sub>IH</sub>	HIGH-level input voltage		2.0	1.5	–	–	V
			4.5	3.15	–	–	V
			6.0	4.2	–	–	V
V <sub>IL</sub>	LOW-level input voltage		2.0	–	–	0.5	V
			4.5	–	–	1.35	V
			6.0	–	–	1.8	V
V <sub>OH</sub>	HIGH-level output voltage	V <sub>I</sub> = V <sub>IH</sub> or V <sub>IL</sub> I <sub>O</sub> = -20 μA	2.0	1.9	–	–	V
		I <sub>O</sub> = -20 μA	4.5	4.4	–	–	V
		I <sub>O</sub> = -20 μA	6.0	5.9	–	–	V
		I <sub>O</sub> = -4.0 mA	4.5	3.7	–	–	V
		I <sub>O</sub> = -5.2 mA	6.0	5.2	–	–	V
V <sub>OL</sub>	LOW-level output voltage	V <sub>I</sub> = V <sub>IH</sub> or V <sub>IL</sub> I <sub>O</sub> = 20 μA	2.0	–	–	0.1	V
		I <sub>O</sub> = 20 μA	4.5	–	–	0.1	V
		I <sub>O</sub> = 20 μA	6.0	–	–	0.1	V
		I <sub>O</sub> = 4.0 mA	4.5	–	–	0.4	V
		I <sub>O</sub> = 5.2 mA	6.0	–	–	0.4	V
I <sub>LI</sub>	input leakage current	V <sub>I</sub> = V <sub>CC</sub> or GND	6.0	–	–	±0.1	μA
I <sub>CC</sub>	quiescent supply current	V <sub>I</sub> = V <sub>CC</sub> or GND; I <sub>O</sub> = 0	6.0	–	–	40	μA

**Note**

1. All typical values are measured at T<sub>amb</sub> = 25 °C.

## Quad 2-input OR gate

## 74HC32; 74HCT32

## AC CHARACTERISTICS

## Family 74HC

GND = 0 V;  $t_r = t_f = 6$  ns;  $C_L = 50$  pF.

SYMBOL	PARAMETER	TEST CONDITIONS		MIN.	TYP.	MAX.	UNIT
		WAVEFORMS	V <sub>CC</sub> (V)				
<b>T<sub>amb</sub> = 25 °C; note 1</b>							
t <sub>PHL</sub> /t <sub>PLH</sub>	propagation delay nA, nB to nY	see Figs 6 and 7	2.0	–	22	90	ns
			4.5	–	8	18	ns
			6.0	–	6	15	ns
t <sub>THL</sub> /t <sub>TLH</sub>	output transition time	see Figs 6 and 7	2.0	–	19	75	ns
			4.5	–	7	15	ns
			6.0	–	6	13	ns
<b>T<sub>amb</sub> = –40 to +85 °C</b>							
t <sub>PHL</sub> /t <sub>PLH</sub>	propagation delay nA, nB to nY	see Figs 6 and 7	2.0	–	–	115	ns
			4.5	–	–	23	ns
			6.0	–	–	20	ns
t <sub>THL</sub> /t <sub>TLH</sub>	output transition time	see Figs 6 and 7	2.0	–	–	95	ns
			4.5	–	–	19	ns
			6.0	–	–	16	ns
<b>T<sub>amb</sub> = –40 to +125 °C</b>							
t <sub>PHL</sub> /t <sub>PLH</sub>	propagation delay nA, nB to nY	see Figs 6 and 7	2.0	–	–	135	ns
			4.5	–	–	27	ns
			6.0	–	–	23	ns
t <sub>THL</sub> /t <sub>TLH</sub>	output transition time	see Figs 6 and 7	2.0	–	–	110	ns
			4.5	–	–	22	ns
			6.0	–	–	19	ns

**Note**1. All typical values are measured at T<sub>amb</sub> = 25 °C.

Quad 2-input OR gate

74HC32; 74HCT32

PACKAGE OUTLINES

DIP14: plastic dual in-line package; 14 leads (300 mil)

SOT27-1

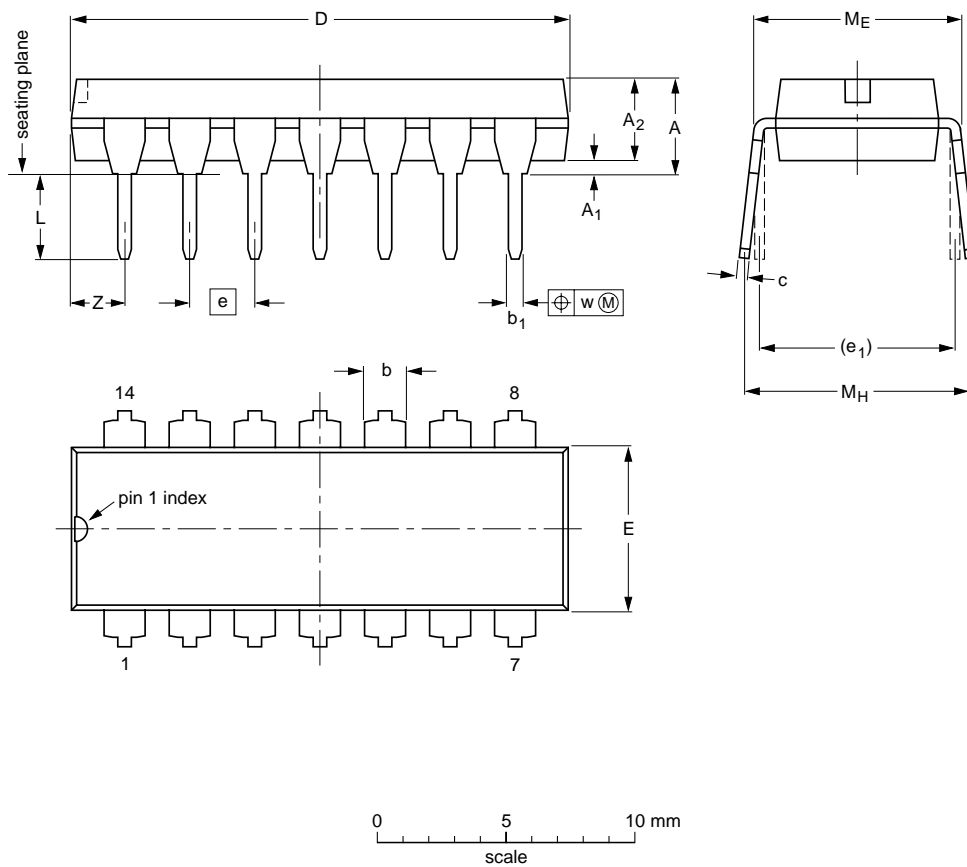

DIMENSIONS (inch dimensions are derived from the original mm dimensions)

UNIT	A max.	A <sub>1</sub> min.	A <sub>2</sub> max.	b	b <sub>1</sub>	c	D <sup>(1)</sup>	E <sup>(1)</sup>	e	e <sub>1</sub>	L	M <sub>E</sub>	M <sub>H</sub>	w	Z <sup>(1)</sup> max.
mm	4.2	0.51	3.2	1.73 1.13	0.53 0.38	0.36 0.23	19.50 18.55	6.48 6.20	2.54	7.62	3.60 3.05	8.25 7.80	10.0 8.3	0.254	2.2
inches	0.17	0.02	0.13	0.068 0.044	0.021 0.015	0.014 0.009	0.77 0.73	0.26 0.24	0.1	0.3	0.14 0.12	0.32 0.31	0.39 0.33	0.01	0.087

Note

1. Plastic or metal protrusions of 0.25 mm (0.01 inch) maximum per side are not included.

OUTLINE VERSION	REFERENCES			EUROPEAN PROJECTION
	IEC	JEDEC	JEITA	
SOT27-1	050G04	MO-001	SC-501-14	



Quad 2-input OR gate

74HC32; 74HCT32

SO14: plastic small outline package; 14 leads; body width 3.9 mm

SOT108-1

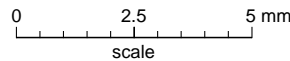
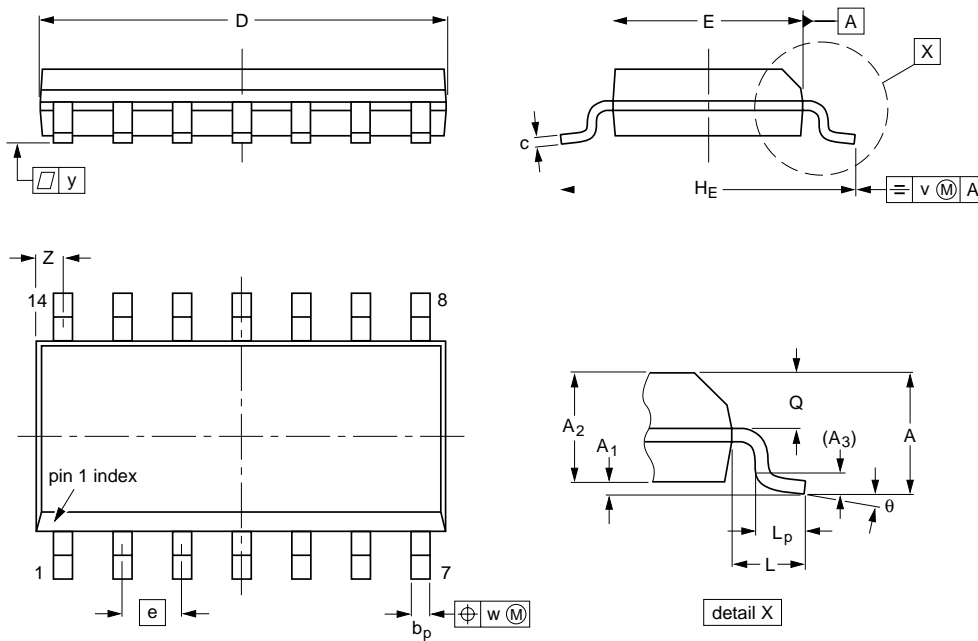

DIMENSIONS (inch dimensions are derived from the original mm dimensions)

UNIT	A max.	A <sub>1</sub>	A <sub>2</sub>	A <sub>3</sub>	b <sub>p</sub>	c	D <sup>(1)</sup>	E <sup>(1)</sup>	e	H <sub>E</sub>	L	L <sub>p</sub>	Q	v	w	y	z <sup>(1)</sup>	θ
mm	1.75	0.25 0.10	1.45 1.25	0.25	0.49 0.36	0.25 0.19	8.75 8.55	4.0 3.8	1.27	6.2 5.8	1.05	1.0 0.4	0.7 0.6	0.25	0.25	0.1	0.7 0.3	8° 0°
inches	0.069	0.010 0.004	0.057 0.049	0.01	0.019 0.014	0.0100 0.0075	0.35 0.34	0.16 0.15	0.05	0.244 0.228	0.041	0.039 0.016	0.028 0.024	0.01	0.01	0.004	0.028 0.012	

Note

1. Plastic or metal protrusions of 0.15 mm (0.006 inch) maximum per side are not included.

OUTLINE VERSION	REFERENCES			EUROPEAN PROJECTION
	IEC	JEDEC	JEITA	
SOT108-1	076E06	MS-012		